



Solid State Automated Attendant & Voice Mail

T40

TEMA TELECOMUNICAZIONI introduces **T40**, a next generation system result of years of experience in Telephony, Voice Mail and Automated Attendants.

T40 is a sophisticated hardware with solid state memory support **Flash Disk** (no hard disk, no stress over mechanical components) and an advanced software fully developed in TEMA Research and Development Area in Italy to integrate all required services for incoming/outgoing calls and managing automation.

All in a single stand-alone system!



Services

- **Automated answering** over all internal lines connected
- **Opening Greeting Service** and customization possible, in a independent way, for each line and for different daily time slots (day/night)
- **Multilevel personalized scripts (IVR)**, max 4 levels
- **In-band DTMF integration** with possibility to reach extensions with quick selection (i.e. one digit each)
- **In-band line tones integration**, with automatic hung-up at the end of the call
- **Possibility** to leave messages to the extensions required if busy or not answering
- **New managing of calls** (for authorized users): possibility to forward/stop incoming call depending on daily time slots.
- **Notification of messages** into mailboxes towards any number (extension or external), separately for daily/weekly time slots.
- **Set of the maximum** number of messages kept in each mailbox, 0 up to 60.
- **Customization**, for each extension, of the length of call's attempts.
- **File Log** of activities, to ease problem solving
- **SMS Notification** of new messages in mailbox
- **Integration** with most common PBX, in order to automatically manage mailboxes and direct signaling on users' extensions.
- **Remote parameters** settings
- **Incoming FAX Detection** and automatic routing on the extension number of the office's FAX machine.

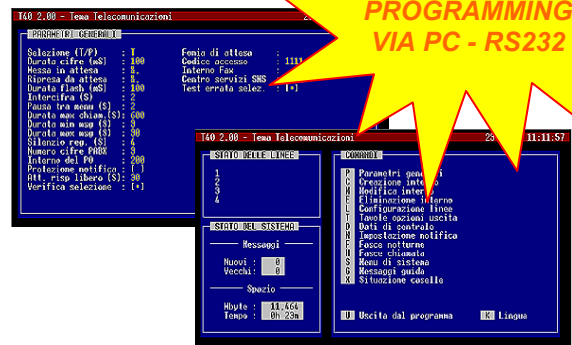

- ➔ **2-4 Analog lines**
- ➔ **From 16 up to 512 Mailboxes**
- ➔ **From 18 up to 72 hours of messages recorded**
- ➔ **4 levels IVR (Interactive Voice Response)**
- ➔ **Output channel for Music/Messages on Hold**
- ➔ **FAX switch on incoming calls on all channels**
- ➔ **Integrations with most common PBX**
- ➔ **Compact Flash Standard Memory**
- ➔ **Easy programming and use**
- ➔ **DSP Digital Signal Processing Technology**
- ➔ **Notification via PBX and via SMS**
- ➔ **Optional modem for remote assistance**
- ➔ **Small dimensions, low consumptions**



Solid State Automated Attendant & Voice Mail

T40

PLATFORM

Hardware System developed by TEMA, all on the single board with Compact Flash Disk mass storage, RAM 8MB, RTC Real Time Clock with Lithium battery, onboard analog line interfaces, DSP (Digital Signal Processing) 225MHz BGA.

FILE SYSTEM TECHNOLOGY

Flash File System on Compact Flash 32-64-128-256-512 MB and over 1GB-2GB-4GB.

INPUT LINES INTERFACE

Analog phone lines: 600 Ohm isolated by transformer
Call Signal (Ring) Sensitivity: Min 20Vrms Max 130Vrms, 15,3...68Hz
Current Loop: From 20 to 50mA, polarity independent
Diaphony : >50dB at 3.000Hz on adjacent channels
Band Pass: from 300 to 3.400Hz
Line Connectors: RJ-11 / RJ-45 (ISDN)

RECORDING AND PLAYBACK

Input Sensitivity: -50....0dBm
AGC Automatic Gain Control
Output transmission power: -9dBm
Memory rate: 28,8 MB/h

TONES / LINE SIGNALS DETECTION

DTMF detection digit: 0 to 9, *, #, A, B, C, D.
Sensitivity: -36dBm - 0dBm
Minimum DTMF length: 43mS; interdigit 40mS
Single tones detection in 300...3300Hz band

tone GENERATION AND DIALLING

DTMF generation digit 0 to 9, *, #, A, B, C, D.
Pulse tone generation ratio 40/60mS, digit 0 to 9
Single/double tone generation in audio band , "Flash" signal

APPROVEMENTS

T40 is compatible with CE requirements on security and EMC according to the current EU laws.

POWER SUPPLY

230VAC, 47...63Hz, 12VA with external power supply T7012A 12VDC

DIMENSIONS / WEIGHT

L130 x H40 x P180 WEIGHT 350g, power supply T7012A 500g

TEMPERATURE - RELATIVE HUMIDITY

Temperature: installation in office, 5° ... 40°, stock -20°....+60°.
Humidity 10%-80% not condensing

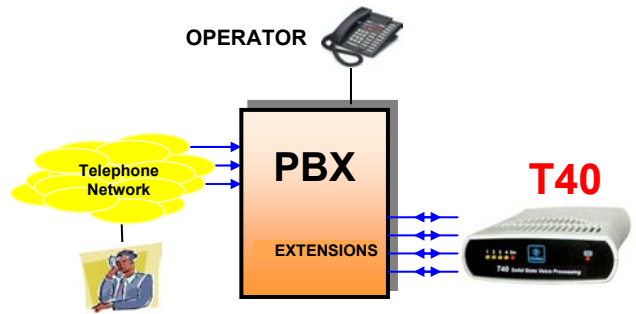

Table or wall mounting



PRODUCT CODES

T40/2	2 Lines,	16 Mailboxes,	18 memory hours
T40/4	4 Lines,	16 Mailboxes,	18 memory hours
T40A/2	2 Lines,	128 Mailboxes,	36 memory hours
T40A/4	4 Lines,	128 Mailboxes,	36 memory hours
T40B/2	2 Lines,	512 Mailboxes,	72 memory hours
T40B/4	4 Lines,	512 Mailboxes,	72 memory hours

OPTIONAL

- T40-PBX integration software for PBX protocols
- T40-UNI software for notification on SMS via GSM
- T40-UP2 upgrade of 2 lines
- PM40/... messages customization

The manufacturer reserves the right to change product characteristic without notice



TEMA TELECOMUNICAZIONI S.r.l.

Web: www.tematic.it e-mail: tematic@tematic.it

Telecommunications– Electronics

Headquarters : Via C.Girardengo, 1/4 20161 Milano MI (Italy) Tel. +39 02 61544.1 Fax +39 02 6152605

Branch Office : Via S.Boccapaduli, 31 00151 Roma RM (Italy) Tel. +39 06 58237920 Fax +39 06 58200328



UNI EN ISO 9001:2000